

# PS72 – General Purpose Mini Pressure Switches

**New!**

- ▶ 10 to 750 psi (0.7 to 51.7 bar)
- ▶ Adjustable or Factory Set
- ▶ Minimal Set Point Change at Low Temperature Extremes

These versatile microswitch based pressure switches are designed for medium pressure OEM applications. They offer all the performance of our proven PS71 model with the low temperature capability of Kapton®.



## Specifications

<b>Switch</b>	SPST; SPDT
<b>Repeatability</b>	See Table 1
<b>Wetted Parts</b>	
<b>Housing</b>	Zinc-Plated Steel (316L stainless steel and brass available)
<b>Diaphragm</b>	Kapton® (polyimide)
<b>O-Ring</b>	Nitrile (other materials available)
<b>Electrical Termination</b>	DIN 43650A IP65; Spade Terminals IP00; Flying Leads IP65; Conduit with Flying Leads IP65; IP option IP66
<b>Proof Pressure</b>	3000 psi (207 bar)
<b>Burst Pressure</b>	6000 psi (414 bar)
<b>Approvals</b>	CE, UL Approved units available
<b>Weight, Approximate</b>	Steel: 0.4 lbs. (0.15 kg)

## Recommended Operating Temperature Limits

Options Selected	Temperature
<b>-RD</b>	-40°F to +250°F (-40°C to +121°C)
<b>No Options</b>	-40°F to +185°F (-40°C to +85°C)
<b>-SP or -10A</b>	-40°F to +212°F (-40°C to +100°C)

## Electrical Switch Ratings

Options Selected	AC	DC
No option or <b>-RD</b>	5 amps @ 125/250 Volts	5 amps resistive, 3 amps inductive @ 28 Volts
<b>-G</b> only or <b>-RD</b> with <b>-G</b>	1 amp @ 125 Volts	1 amp resistive, 0.5 amp inductive @ 28 Volts
<b>-10A</b> only or <b>-SP</b> without <b>-G</b>	10.1 amps @ 125/250 Volts	—
<b>-SP</b> with <b>-G</b>	2 amps @ 125/250 Volts	—

## Dimensions

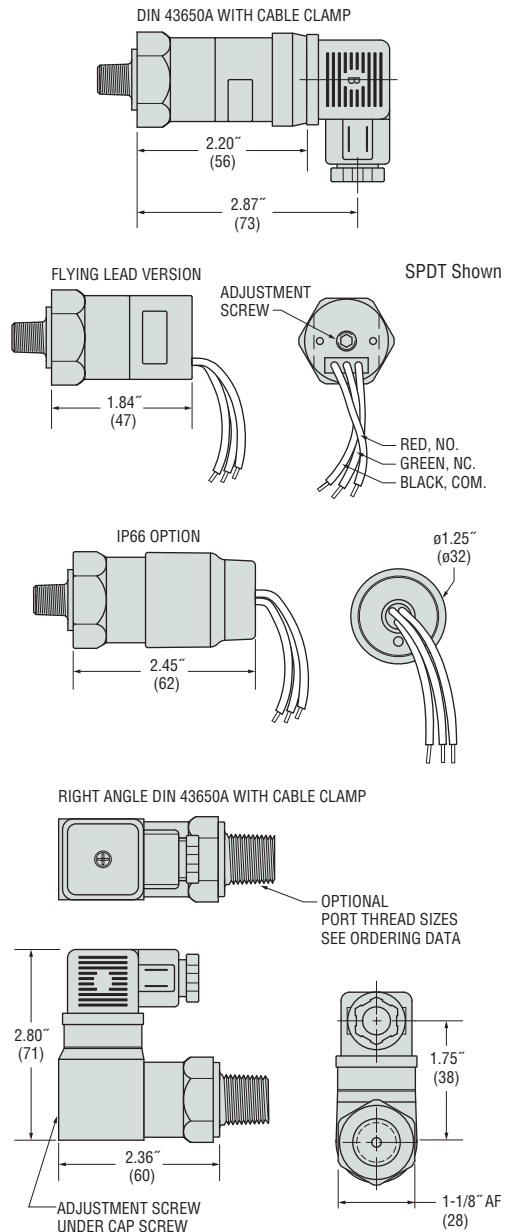

PRESSURE SWITCHES

## How To Order

Use the **Bold** characters from the chart below to construct a product code. Please reference Notes.

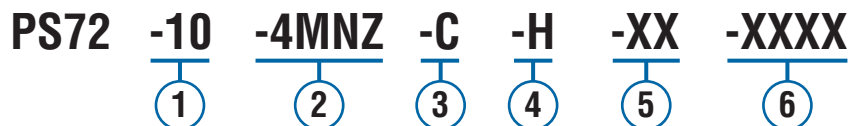

### ① Pressure Range Code

Insert Pressure Range Code from Table 1, below.

### ② Pressure Fitting<sup>1</sup>

12L14 Zinc-Plated Steel

- 2MNZ=1/8" NPTM
- 4MNZ=1/4" NPTM
- 2MGZ=1/8" BSPM (G type)
- 4MGZ=1/4" BSPM (G type)
- 4MSZ=7/16"-20 SAE Male
- 6MSZ=9/16"-18 SAE Male

316 Stainless Steel

- 2MGS=1/8" BSPM (G type)
- 4MNS=1/4" NPTM
- 4MGS=1/4" BSPM (G type)

### ③ Circuit

- A=SPST/N.O.
- B=SPST/N.C.
- C=SPDT

### ④ Electrical Termination

- SP=Spade Terminals<sup>2</sup>
- FLXX=Flying Leads<sup>3</sup>
- FLSXX=Flying Leads w/PVC Shrink Tubing<sup>3</sup>
- ELXX=1/2" NPT Male Conduit w/Flying Leads<sup>4</sup>
- CABXX=18 AWG PVC Cable<sup>5</sup>
  - H=DIN 43650A Male Half Only<sup>6</sup>
  - HR=Right Angle DIN 43650A Male Half Only<sup>6</sup>
  - HC=DIN 43650A 9mm Cable Clamp<sup>6</sup>
  - HCR=Right Angle DIN 43650A 9mm Cable Clamp<sup>6</sup>
  - HN=DIN 43650A with 1/2" Female NPT Conduit<sup>6</sup>
  - HNR=Right Angle DIN 43650A with 1/2" Female NPT Conduit<sup>6</sup>

### ⑤ Options<sup>7</sup>

- 10A=10A @ 125/250 VAC Max. Rating
- G=Gold Contacts  
(for loads less than 12 mA @ 12 VDC)
- RD=Reduced Differential  
(25% reduction typical)
- IP=Ingress Protection<sup>8</sup>
- OXY=Oxygen Cleaned<sup>9</sup>
- R=Restrictor (low damping coefficient) Brass
- SR=Spiral Restrictor (high damping coefficient)  
300 Series Stainless Steel<sup>10</sup>
- WF=Weather Pack Connector, Female
- WM=Weather Pack Connector, Male
- DE=Deutsch Connector, Male, DT04 Series

### ⑥ Fixed Set Point (optional)

- A. Specify set point **-FS**  
(in PSI or BAR, see example)<sup>11</sup>
- B. Set Point Actuation  
**R** on Rising Pressure  
**F** on Falling Pressure  
Example: **-FS2BARF** for 2 BAR Falling  
or **-FS20PSIR** for 20 PSI Rising

Notes:

1. Other fittings available. Consult factory.
2. Requires **-10A** or **-G** option. (20% increase in deadband typical)
3. 1/8" is standard. Specify lead length in inches (max. 48"). e.g. **-FL18** or **-FLS30**.
4. 1/8" is standard. Specify lead length in inches (max. 48"). e.g. **-EL18** or **-EL30**.
5. 3/6" is minimum. Specify cable length in inches. e.g. **-CAB36** or **-CAB120**.
6. DIN connectors require **-C** SPDT circuit.
7. Options **-10A**, **-G** or **-RD** cannot be combined.
8. Ingress Protection is available only with **-FL**, **-FLS** or **-CAB** Electrical Termination choices. Ingress Protection requires Fixed Set Point **-FS**.
9. Requires stainless steel housing.
10. **-SR** will result in wider deadbands and slower response times.
11. Set Point must be within Pressure Range selected in Step 1.

Table 1 — Pressure Range Codes

Pressure Range Code	Pressure Range	Repeatability	Average Deadband*
<b>10</b>	10-30 psi (0.7-2.1 bar)	±1.5 psi (0.103 bar) +3% of setting	3.5 psi (0.28 bar) +12% of setting
<b>20</b>	25-75 psi (1.7-5.2 bar)	±2.5 psi (0.172 bar) +3% of setting	3.5 psi (0.28 bar) +12% of setting
<b>30</b>	65-300 psi (4.5-20.7 bar)	±5.0 psi (0.345 bar) +3% of setting	20 psig (1.38 bar) +12% of setting
<b>40</b>	250-750 psi (17.2-51.7 bar)	±15 psi (1.03 bar) +3% of setting	45 psig (3.10 bar) +13% of setting

\* These numbers are for the standard microswitch. With either the **-SP** or **-10A** option, the values are typically 20% greater than those listed. With the **-RD** option, the values will be typically 25% less than those listed. In certain applications deadband can be tailored and controlled to customer specifications. Consult factory for details.